

A High Performance Full Wave Crystal Detector Receiver +6 dB Gain

OddMix.com - Technical Note - Crystal Radio - TN070417 - Karl Nagy

The radio described here is unique in that it allows quality, higher volume radio reception even in areas without any outside power. This germanium, point contact diode detector radio produces a six-decibel (6-dB) gain, which is twice the usual audio output produced by single diode sets. It does that, however, at the expense of some slight extra work and components.

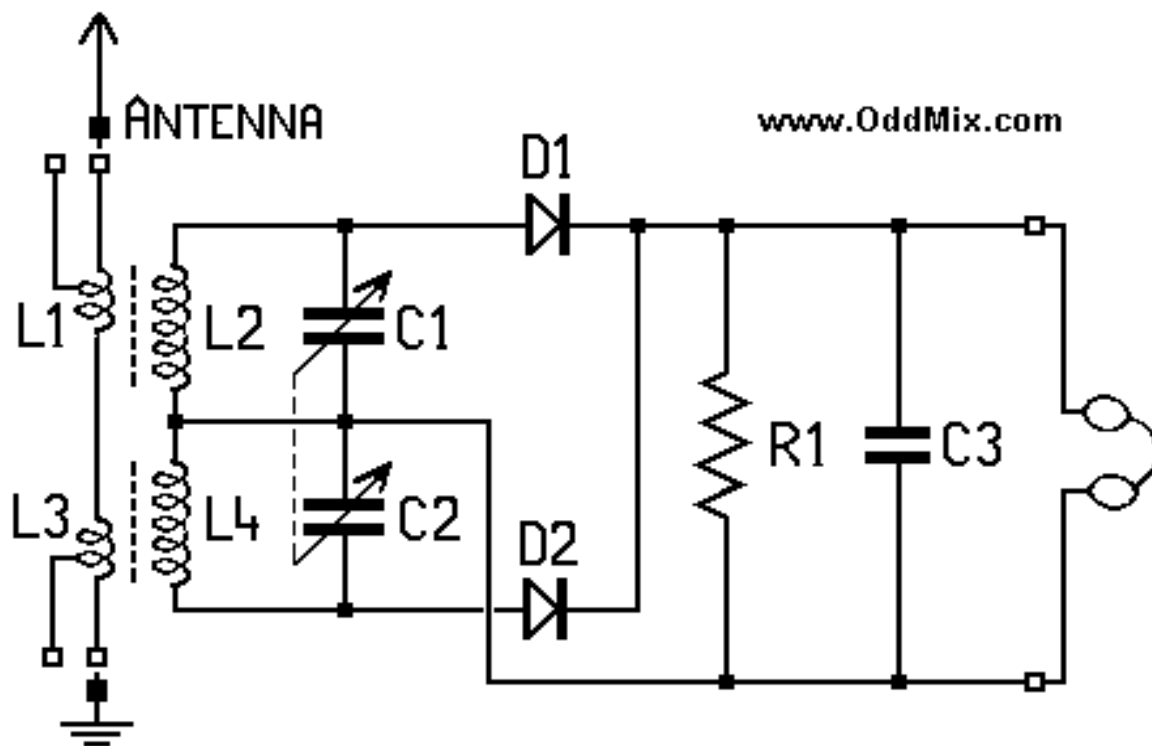

Figure 1. High performance crystal detector radio.

Figure 2 shows the schematic diagram of this high power version of the detector radio. This set uses two 1/4-inch coil forms with ferrite screws in each. The primary antenna coils L1 and L3 are 40 turns made with 10x0.05 MM Litze wire, taps are at the 20 turn half point. L2 and L4 are 70 turns with 10x0.05 MM Litze wire, with RF ferrite tuning screws. Their design value is 200 uH (micro Henry) for each coil. C1 and C2 are connected together, such that only one knob may be needed for tuning (a dual gang capacitor).

Parts list for high efficiency crystal detector radio:

- L1 - Primary, Antenna coil 1 - 40 turns - tap at 20
- L3 - Primary, Antenna coil 2 - 40 turns - tap at 20
- L2 - Secondary coil 1 - 70 turns - 200 uH
- L4 - Secondary coil 2 - 70 turns - 200 uH

- C1 - Rotary Capacitor 500 pF - Dual unit
- C2 - Rotary Capacitor 500 pF - Dual unit
- D1 - Diode, Germanium, point contact
- D2 - Diode, Germanium, point contact
- R1 - Load resistor 200 K, for crystal phones only
- C3 - Filter capacitor 1 nF, for magnetic phones only

The components and the wiring should be symmetrical as much as possible. Good soldering techniques are required. If possible, D1 and D2 should be a matched set. These diodes should also be protected against too much heat and static charge damage. A heat sink or a pair of pliers should be used on the diode leads between the solder joint and the diode body while soldering to conduct away damaging excess heat.

When starting up, close the rotary capacitor fully. Slowly rotate the capacitor to open it until the first station is found. Now rotate the slugs inside of the L1 - L2 coil form until sound volume is maximized. If the rotary capacitor has trimmer capacitors, then open the capacitor all the way, then slowly rotate it in the opposite (closed) position until the first station is found. Adjust the C1's trimmer capacitor until maximum sound volume is obtained. Fully close the capacitor and repeat the procedure from the beginning of this paragraph, until no further improvements are obtainable. Now do the same with the L3 - L4 coil. Repeat the procedure until no further improvements possible in the sound volume. Use a signal generator and an audio voltmeter is available, as they permit a much more exact alignment.

Since ferrite has higher magnetizing losses than air, an air core coil would increase the overall receiver efficiency. Because the ferrite slugs are used to equalize the two coil's inductance, the aircore coils should use bifilar winding techniques. Also, the number of turns changes, but heavier, solid wires can also be used instead of the Litz. Wound L2 and L4 with an extra wire between them. The purpose of this extra wire is to serve as a spacer. Remove this winding after the coil is completed. Wound the coil tightly unto the coil form, and secure the ends well upon completion.

[Previous Page](#)



Web www.oddmix.com